

# REDUCTION OF CO-CHANNEL INTERFERENCE IN CELLULAR NETWORK USING SECTORIZATION METHOD

CHUKWUNYERE IKECHUKWU CHIDIEBERE<sup>\*</sup>, BOURDILLON O OMIJEH<sup>\*</sup>

## ABSTRACT

In this work, cell sectoring is used to reduce co channel interference in the reverse link of a wireless cellular network. The advantage that the number of interfering mobiles decreases with respect to the increase in the number of sectors is taken to sectorize a cell with 120 degrees opening per sector. Only the first tier is considered owing to the fact that the interference from other tiers is negligible.

Simulation of the result is done in Matlab and it is shown in terms of the signal-to-interference ratio (SIR), Bit error rate (BER), the received signal constellation which is shown in three categories namely: Result without sectoring, Result with sectoring, combined effect of result with sectoring and increase transmit power of the desired signal. It is deduced that with three sectored antenna incorporated, signal-to-interference ratio and Bit error rate improve by 0.77dB (21.8%) and 5.6dB (55%) respectively while the constellations of the received signal is better. A little more increase in the transmit power of the desired signal results to zero bit error and more appreciable improvement of about 4.5dB in signal-to-interference ratio while the constellation of the received signal is better.

**KEYWORDS:** Modeling, CDMA, Sectoring, Wireless, Cellular, Constellations, Network.

## INTRODUCTION

A cellular network is a mobile network that provides services by using a large number of low power base stations, each covering only a limited area. This limited power makes it possible to reuse the same frequency a few cells away from the base station without causing interferences. In this way a geographical large area can be covered with only a limited set of frequencies. A cellular network is a very efficient manner of using the scarce frequency resources. The objective of

frequency reuse and channel assignment scheme is to minimize the call blocking and the call-dropping probabilities (Hale, 1980). The size of a cell can vary according to the number of users that have to be served in a certain area and the amount of traffic per user. If there is much traffic in an area the cell size will be smaller than in rural areas. The key characteristic of a cellular network is the ability to reuse frequencies to increase both coverage and capacity.

---

<sup>\*</sup> Department of Electrical and Electronics Engineering, University of Port Harcourt.

**Correspondence E-mail Id:** editor@eurekajournals.com

In a cellular radio system, a land zone to be provided with radio administration is separated into general molded cells, which can be hexagonal, square, roundabout or some other unpredictable shapes, albeit hexagonal cells are regular. Every one of these cells is relegated different frequencies which have relating radio base stations. The gathering of frequencies can be reused in different cells, gave that similar frequencies are not reused in contiguous neighboring cells as that would cause Co-channel

impedance. The expanded limit in a cellular system, contrasted and a system with a solitary transmitter, originates from the way that a similar radio recurrence can be reused in an alternate territory for a totally unique transmission. In the event that there is a solitary plain transmitter, just a single transmission can be utilized on any given recurrence. Lamentably, there is definitely some level of obstruction from the flag from alternate cells which utilize a similar recurrence (Ahaneku and Chijindu, 2013).

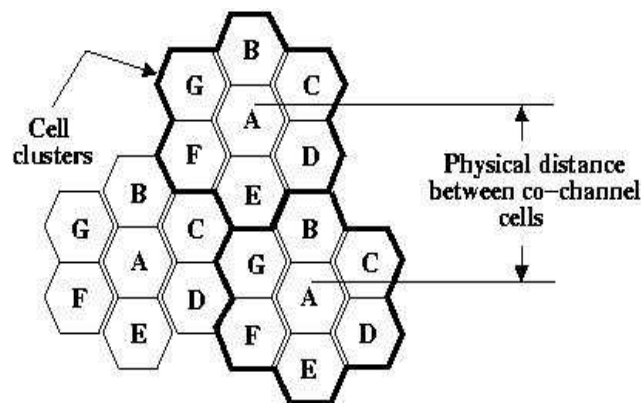

Figure 1. Schematic diagram of frequency reuse

In cellular mobile communication, frequency spectrum is a precious resource divided into non-overlapping spectrum bands which are assigned to different cells. However, after certain geographical distance, frequency is reused according to figure 1 above. Owing totally to this phenomenon called frequency reuse, Co-channel interference arises in the cellular mobile network. The Co channel interference seriously impact network performance, resulting in poor speech quality, lower data rates, dropouts and even complete loss of voice calls.

### THEORITICAL BACKGROUND

The signal to interference ratio (SIR) decides the nature of administration experienced by the base station backward channel (mobile to base station) and by the mobile client in the forward channel (base station to mobile) in a CDMA system. Cochannel interference is a constraining factor in a cellular mobile radio system. In this manner, registering the signal to interference

ratio is critical for deciding scope, limit, and nature of administration in a CDMA system. This thesis examines the signal to noise ratio (S/N) due to the additive white Gaussian noise (AWGN), and co-channel interference in the reverse channel (mobile to base station) of CDMA for a cellular architecture.

Reliable with current CDMA plans, we accept that there are separate frequency bands for the switch connect (mobile to base) and the forward connection (base to mobile). In this proposal, the suspicion is that all transmitters, regardless of whether in bases or in mobiles, utilize omnidirectional antennas aside from sectoring plan for cochannel interference lessening in which directional reception apparatus is being utilized. These two presumptions infer that any mobile in the system encounters interference from every base station, yet does not encounter interference from different mobiles (forward connection). Correspondingly, a given base station encounters interference from all mobiles in the system,

however not from other base stations (invert connect). In this paper, the turnaround interface is viewed as it were. Albeit all co-channel cells meddle with each other, we will dissect just the main level since the interference from ensuing levels is insignificant when contrasted with the

first and second levels. Utilizing a hexagonal cell design, the reference cell O and the adjoining first (marked by a solitary letter) and second level (named by twofold letters) cells are appeared in Figure 2.

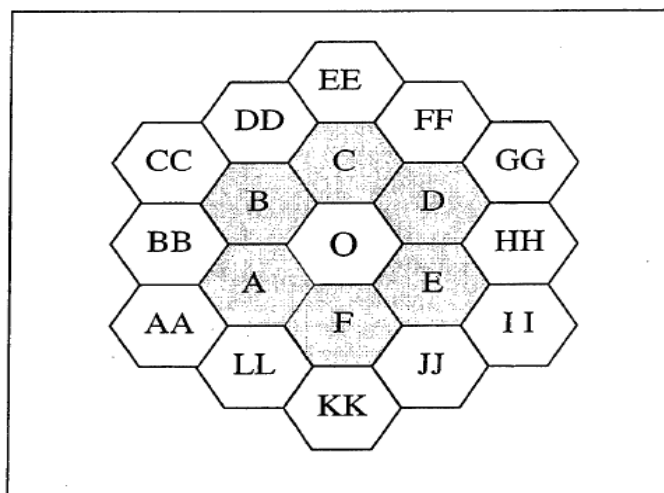

Figure 2. Reference cell with the first tier (gray shaded) and second tier co-channel cells

To derive an expression for the signal to interference ratio due to co-channel interference, we have to consider several factors: additive white Gaussian noise (AWGN), the path loss exponents for each of the cells and the ratio of the power of the interfering co-channel users to the desired user's power as received by the mobile station.

We can obtain the generalized expression for the signal to interference ratio (SIR) of the reverse link of the CDMA system as follows:

$$\frac{S}{I} = \left[ \left( \frac{E_b}{N_0} \right)^{-1} + \left( \frac{S}{I} \right)_{in-cell}^{-1} + \left( \frac{S}{I} \right)_{tier-1}^{-1} + \left( \frac{S}{I} \right)_{tier-2}^{-1} \right]^{-1} \quad (3.1)$$

Where  $E_b/N_0$  is the signal energy per bit-to-noise ratio,  $N_0$  is the one-sided noise power spectral density,  $E_b = P_0 T_b$  is the average bit energy,  $T_b$  is the bit duration,  $P_0$  is the signal power of the desired user.

The second term in eq. (3.1) is the intra-cell interference caused by the other users in the reference cell given as

$$\left( \frac{S}{I} \right)_{in-cell} = \frac{E_k}{\gamma \sum_{i=1}^K E_i} \quad (3.2)$$

where  $\gamma = 2/3N$  is the normalized variance of the multiuser interference (MUI) within the reference cell,  $E_k$  is the bit energy of the desired mobile,  $E_i$  is the bit energy of the undesired mobiles within the reference cell, and  $K$  is the number of users in the cell.

We also assume that power control (each mobile transmitter power level is controlled by its base station) is employed within the each cell, and all mobiles have equal signal power at the base station within the cell, i.e.,  $E_j = E_k = E_b$ .

Assuming a channel activity factor  $\alpha$  (such as voice activity) and substituting into (3.2), we obtain:

$$\left( \frac{S}{I} \right)_{in-cell} = \frac{E_b}{\frac{2\alpha}{3N} \sum_{i=1}^K E_b} = \frac{3N}{2(K-1)\alpha} \quad (3.3)$$

$$\left( \frac{S}{I} \right)_{in-cell}^{-1} = \frac{2(K-1)\alpha}{3N} \quad (3.4)$$

Where K is the number of users in the reference cell.

The third term in (3.1) is the first tier co-channel interference at the base station of interest and is given as:

$$\left(\frac{S}{I}\right)_{tier-1}^{-1} = \sum_{i=1}^{i_0} \frac{2\alpha}{3N} \left( \sum_{k=1}^{K_i} \frac{P_{ik}}{P_o} \right) \quad (3.5)$$

where  $P_o$  is the average received signal power at the reference base station,  $i_0$  is the number of the first tier co-channel cells,  $K_i$  is the number of users within the  $i^{th}$  co-channel cell,  $P_{ik}$  is the average received power at the reference base station due to the  $k^{th}$  user in the  $i^{th}$  co-channel cell, and  $\alpha$  is the channel activity factor.

The last term in (3.1) is the second-tier co-channel interference at the base station of interest and is given as:

$$\left(\frac{S}{I}\right)_{tier-2}^{-1} = \sum_{j=1}^{j_0} \frac{2\alpha}{3N} \left( \sum_{k=1}^{K_j} \frac{P_{jk}}{P_o} \right) \quad (3.6)$$

where  $P_o$  is the average received signal power at the reference base station,  $j_0$  is the number of second tier co-channel cells,  $K_j$  is the number of

users within the  $j^{th}$  co-channel cell,  $P_{jk}$  is the average received signal power at the reference base station due to the  $k^{th}$  user in the  $j^{th}$  co-channel cell, and  $\alpha$  is the channel activity factor. Hence the signal to interference ratio of the signal is given by:

$$S/I = \frac{P_o / 4\pi P^2}{\sum_{i=1}^N \frac{P_o}{4\pi D_i^2}} \quad (3.7)$$

Where  $p$ = distance between mobile station and central base station.

To simplify the calculation of the distances between the reference base station and the interfering mobile stations in the co-channel cells, we locate the reference base station at the center of a x-y coordinate system, that is the coordinates of the reference base station is (0,0). We can then easily obtain the coordinates of the interfering mobile stations as shown in Figure 3. The distance between an interfering mobile station and the reference base station is

$$d_{0,ik} = \sqrt{x_{ik}^2 + y_{ik}^2} \quad (3.8)$$

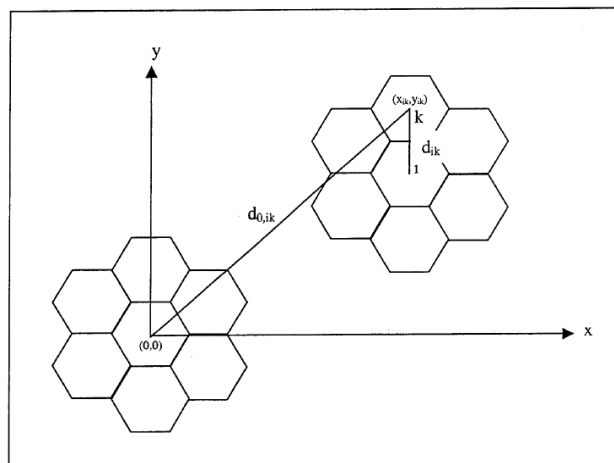

Figure 3. The coordinates of the reference base station and an interfering mobile station

where  $(x_{ik}, y_{ik})$  is the coordinate of the  $k^{th}$  mobile station in the  $i^{th}$  co-channel cell, relative to the reference base station. The location of each mobile station in the first and second co-channel

cells is determined and its distance to the reference base station computed.

We also have to know the distance between the interfering mobile station and its base station to

derive transmitted signal power of the interfering mobile station.

$$d_{ik} = \sqrt{3}R, \quad i \neq 1, \quad (3.9)$$

From Figure 3, we obtain the distance between each mobile station and its own base station as

Where the cell radius R is the distance from the center of the cell to any of the six vertices of the small hexagons.

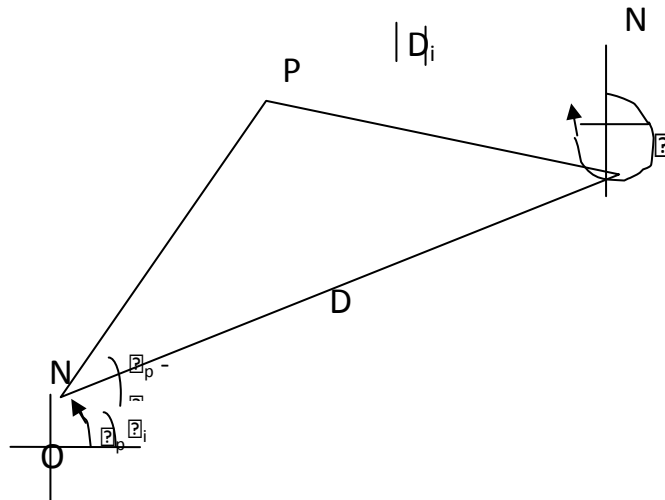

Figure 4. Diagram to show the distances from the central base station and the interfering base station.

From Cosine rule

$$p_r = \frac{p_o}{4\pi D_i^2} \quad (3.11)$$

$$|D| = \sqrt{P^2 + D^2 - 2PD \cos(\theta_p^2 - \theta_i^2)} \quad (3.10)$$

The power received by a mobile station from all the interfering base stations plus the central base station is given as

Where,

The power received by a mobile station from all the interfering base stations plus the central base station is given as

P= distance between mobile station and central base station.

$$p_r = \frac{p_o}{4\pi P^2} + \sum_{i=1}^6 \frac{p_o}{4\pi D_i^2} \quad (3.12)$$

D= Distance between central base station and interfering base station

The S/I ratio can be calculated as

$\theta_i$  = Bearing of interfering base station with respect to central base station.

$$S/I = \frac{\frac{p_o}{4\pi P^2}}{\sum_{i=1}^6 \frac{p_o}{4\pi D_i^2}} \quad (3.13)$$

$\theta_p$  = Bearing of mobile station with respect to central base station.

The power received by a mobile station at a distance D from a base station is given as

From sine rule and adjustment by  $\pi$  the bearing of the mobile station from the interfering station is given by

$$\theta_{pi} = \theta_i - \sin^{-1} \left[ \sin\left(\frac{\theta_p - \theta_i}{p}\right) \times D_i \right] + \pi \quad (3.14)$$

Where

$P_o$  = Power of the transmitted signal from the base station

A standout amongst the most imperative procedures accessible to diminish the co-channel interference, and consequently, increment the limit of a CDMA cellular system is sectoring. Sectoring is the substitution of the base station's single omni-directional receiving wire with a few directional antennas. These are utilized as a part of both for getting and transmitting from and to a specific sector of the cell as appeared in Figure 4.

## METHODOLOGY

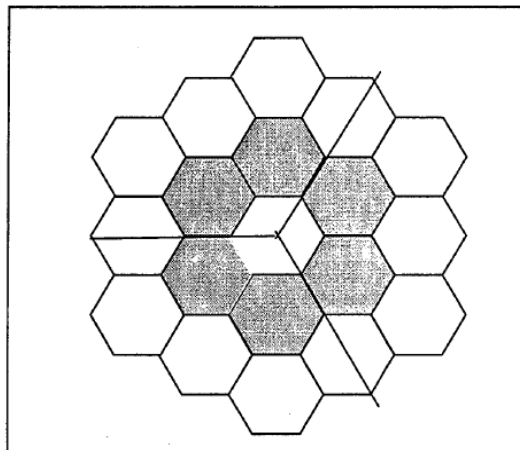

Figure 5.120 sectoring with the first (gray shaded) and second tier co-channel cells.

This is an instance of impeccable directional antennas; there is a sharp separation between the sectors. Along these lines, the cell is partitioned into  $D$  sectors. Sectoring into  $D$  sectors produces opening edges of  $360^\circ/D$ . In light of impeccable sectoring, the quantity of meddling mobiles diminishes with the expansion in the quantity of sectors. As clarified beforehand in this part, since we expect that every cell comprises of 7 "little hexagons" and every client is at the focal point of one of these little hexagons, the clients are uniformly conveyed among the cells. Hence, the quantity of clients in every sector is the total number of clients separated by number of sectors. In this manner, the power interference ratio between one sector to the entire cell is the ratio of number of clients in that sector to the total number of clients in the cell.

During sectoring, a sectoring antenna has the directional field pattern given as

$$E = E_0 \cos^2 \frac{\theta}{2} \quad (3.15)$$

Where  $\theta$  is the azimuth angle.

The power therefore received at a distance  $D$  is given by

$$P = \frac{P_0 \cos^4 \frac{\theta}{2}}{4\pi D^2} \quad (3.16)$$

### Power received from central station.

The mobile is at a distance  $P$  from the central station. Therefore the received power from the central base station is given as

$$P_r = \frac{P_0 \cos^4 \frac{\theta}{2}}{4\pi P^2} \quad (3.17)$$

**POWER RECEIVED FROM INTERFERING STATION**

Table 1. Interfering signal power based on the spatial orientation of the Mobile station, central station and interferer

Central Station position from the interferer $\theta_i$	Magnitude of the Interferer Power $P_r(\theta_i)$
30°	$\frac{p_0 \cos^4 \left(\frac{\pi}{12}\right)}{4\pi D_i^2}$
60°	$\frac{p_0 \cos^4 \left(\frac{4\pi}{6}\right)}{4\pi D_i^2}$
90°	$\frac{p_0 \cos^4 \left(\frac{\pi}{12}\right)}{4\pi D_i^2}$
120°	$\frac{p_0 \cos^4 \left(\frac{5\pi}{6}\right)}{4\pi D_i^2}$
150°	$\frac{p_0 \cos^4 \left(\frac{11\pi}{12}\right)}{4\pi D_i^2}$
180°	$\frac{p_0 \cos^4 \pi}{4\pi D_i^2}$

The total power from Interfering Stations

$$= \frac{1}{4\pi D_i^2} \sum_{i=1}^6 P_0 \cos^4 \frac{(\theta_i + \pi)}{2} \quad (3.20)$$

$$\theta_i = \left(\frac{\pi}{6}, \frac{\pi}{3}, \frac{\pi}{2}, \frac{2\pi}{3}, \frac{5\pi}{6}, \pi\right)$$

The S/I ratio can be calculated thus as

$$S/I = \frac{\frac{P_0 \cos^4 \left(\frac{\theta}{2}\right)}{4\pi P^2}}{\frac{1}{4\pi D_i^2} \sum_{i=1}^6 P_0 \cos^4 \frac{(\theta_i + \pi)}{2}} \quad (3.21)$$

When sectoring is applied, the location of each mobile station in the first tier co-channel cells is determined and its distance to the reference base station computed using cosine rule as shown in the equation 3.10 above:

$D_i$  = Distance between interfering base station and mobile station.

$\theta_i$  = Bearing of interfering base station with respect to central base station.

$\theta_p$  = Bearing of mobile station with respect to central base station.

With application of Sectoring, the power of the transmitted signal being the power received by mobile stations from all base station is shown in equation (3.21) above

Where the angle  $\theta_{pi}$  = Bearing of mobile station with respect to interfering station, as shown the equation (3.14) above

That is the reference angle to which the sectoring angles are being measured which determines the direction of the antenna and its coverage to a particular number of interfering mobile cells.

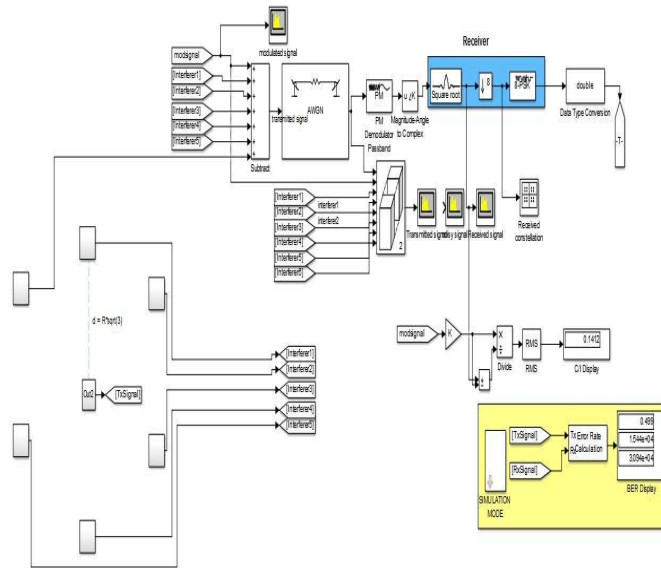

Figure 6. Matlab Model of the cellular Network

The communication system in this work includes these components: A transmitter, which creates a PSK (phase shift key), modulated signal and applies a square root raised cosine filter. The result is the “original signal” to which the interference signals is added. Six interferers, Interferer1, Interferer2, up to interferer6, each of which is similar to the transmitted signal but has a modifiable frequency offset and power gain. A sum block in the model adds the six interfering signals to the original signal. By default, all the interferers are active; however, you can deactivate one or all interferers. Another

component is the additive white Gaussian Noise (AWGN). It is additive because it is added to any noise that might be intrinsic to the system, white because it has uniform power across the frequency band for the system and Gaussian because it has a normal distribution in the time domain with an average time domain value of zero. AWGN is added to mimic the effect of many natural random processes that occur in the system. A receiver, which filters, down-samples, and demodulates the received signal. The fully modeled system is shown in figure 6 above.

**SIMULATIONS, NUMERICAL RESULTS AND DISCUSSIONS**

Table 3.Data collected

S/NO	PARAMETERS	VALUES
1.	Distance between mobile station central base station, P	4m
2.	Distance between central base station and interfering base stations, D	6m
3.	Beam width, BW	200e3
4.	Signal power of the actual signal, P <sub>0</sub>	1.0dB
5.	Signal band width, B	2MHz
6.	Signal type	PSK
7.	Signal sampling time	1e-6s
8.	Signal bit rate	1e6/s
9.	Up-sampling filter factor	8
10	Inclination angle of base station to mobile station	45 Degrees



**RESULT ANALYSIS OF CASE 1 SIMULATION**

The first simulation case was carried out without incorporating the proposed cochannel reduction scheme into the system. At this point the results

are presented and scoped out to graphically illustrate the behaviour of the system operating with six interfering signals transmitted alongside with the actual signal. The result is as shown below in figure 4.1.

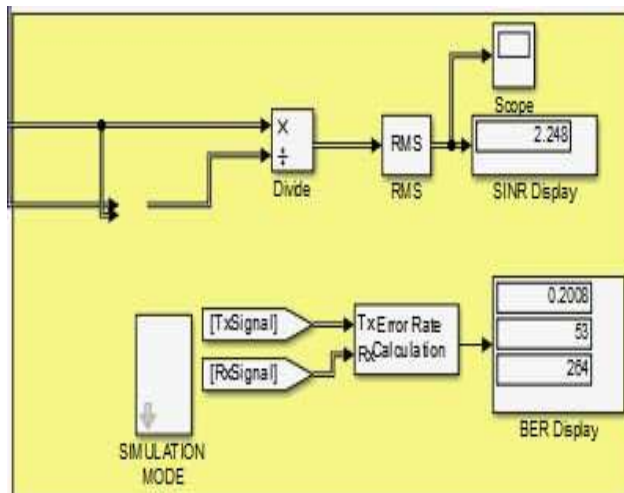

Figure 4.1.Result of Simulation case 1 showing S/I ratio and BER

The diagram shows the result of the simulation when run without Sectoring using matlab. It can be seen that the spectrum of all the interfering signals occupy the same spectral portion of the original signal. The effect of this is an increased Bit Error rate (BER) of 4.62dB and a reduced signal to interference ratio (S/I) of 3.53dB. The constellations of the received signal buttress the fact that the receiver is prone to make a lot of decision errors. It is because the receiver selects, as its estimate of what was actually transmitted,

that point on the constellation diagram which is closest in a Euclidean sense to that of the received symbol. Thus it will demodulate incorrectly if the corruption has caused the received symbol to move closer to another constellation point than the one transmitted. The constellation diagram visualizes the phenomena similar to those an eye pattern does for one-dimensional signal

The waveforms describing the system responses is as shown below in figure 4.2 to figure 4.4

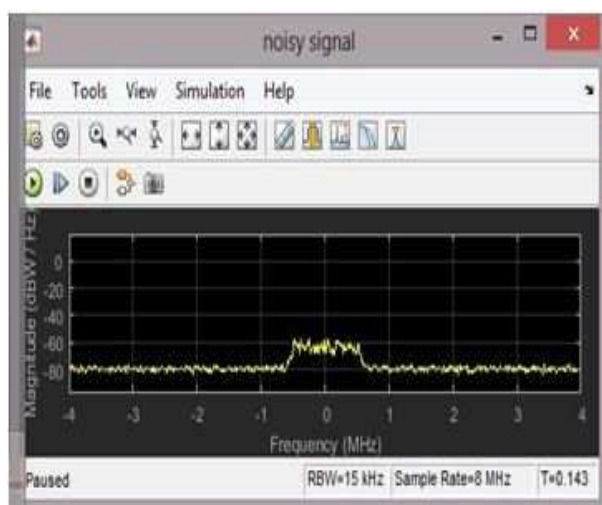

Figure 4.2.Noise signal for case 1

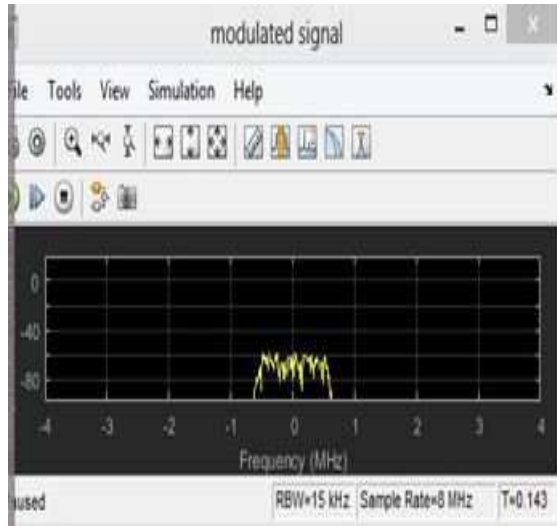

Figure 4.3. Modulated signal for case 1

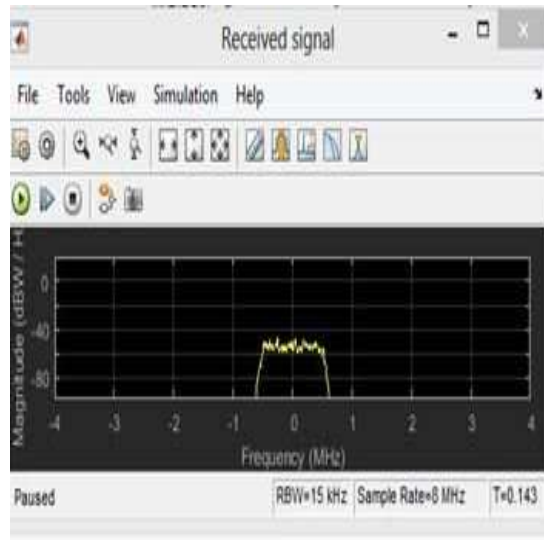

Figure 4.4. Received signal for case 1

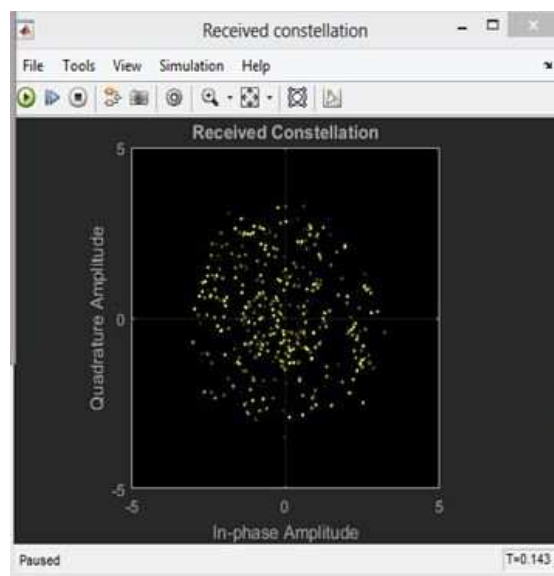

Figure 4.5. Received constellation for case 1 simulation

**RESULT ANALYSIS OF SIMULATION CASE 2**

The second simulation case covers the simulation when sectoring is incorporated in to the system

model. The mathematical analysis shown in section 3.5 is added to the model and it is activated when 2 is selected at simulation mode block. The result is shown in figure 4.6

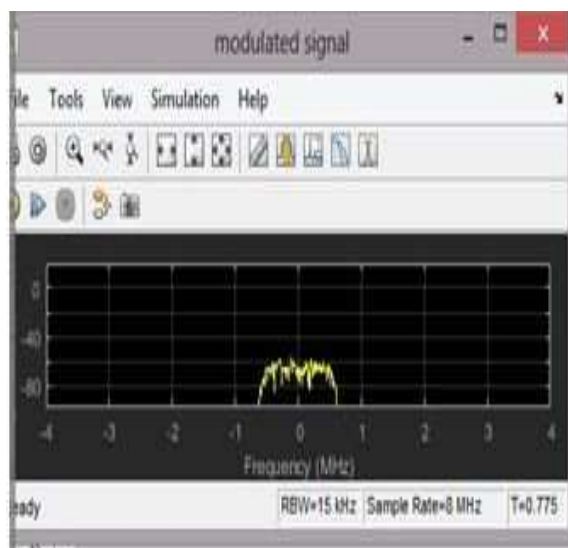

Figure 4.6.Simulation result of case 2 showing S/I ratio and BER

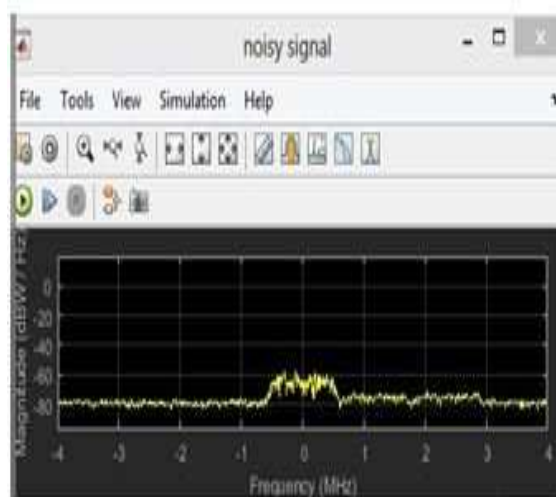

Figure 4.7.Noise signal for case 2 simulation

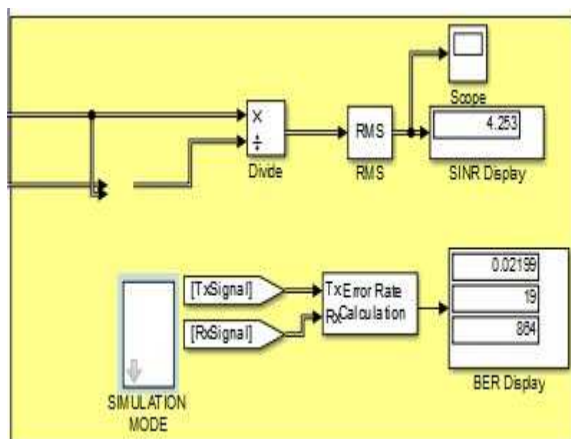

Figure 4.8.Modulated signal for simulation case 2

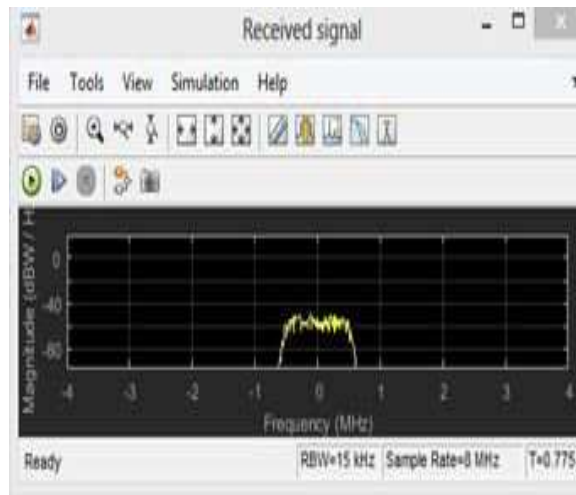

Figure 4.9. Received signal of Simulation case 2 with sectoring

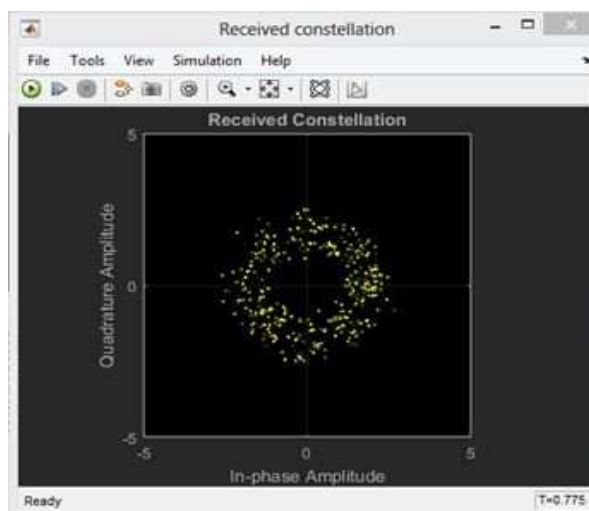

Figure 4.10. Received constellations for simulation case 2

**RESULT ANALYSIS OF CASE 3 SIMULATION**

The simulation case 3 is the simulation carried out with sectoring incorporated and increased

power of Transmitted signal. The result is also graphically illustrated as shown in figure 4.11.

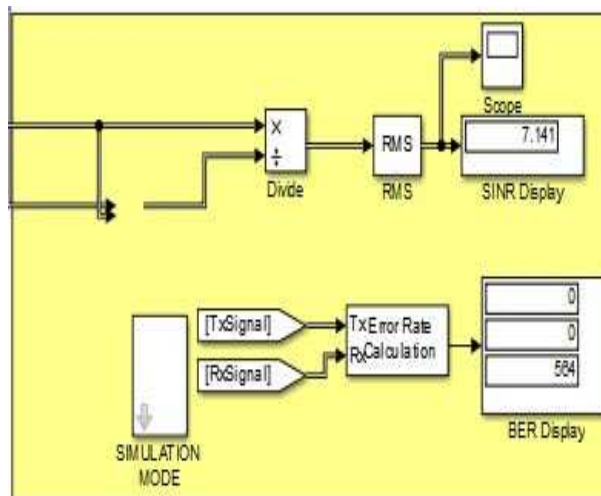

Figure 4.11. Simulation result case 3 showing S/I and BER

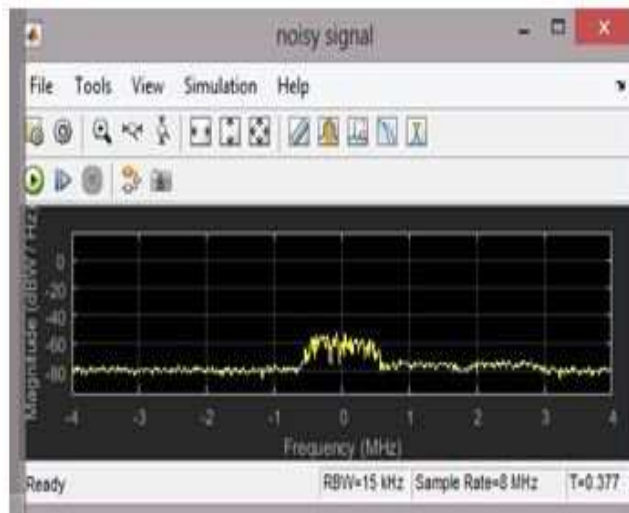

Figure 4.12.Noise signal for simulation case 3

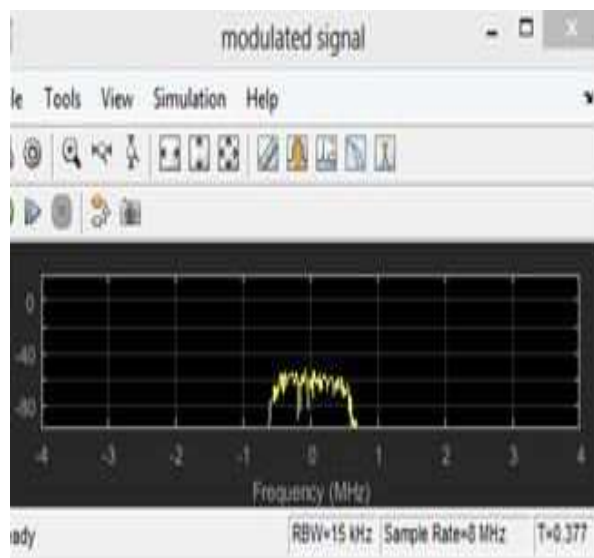

Figure 4.13.Modulated signal for simulation case 3

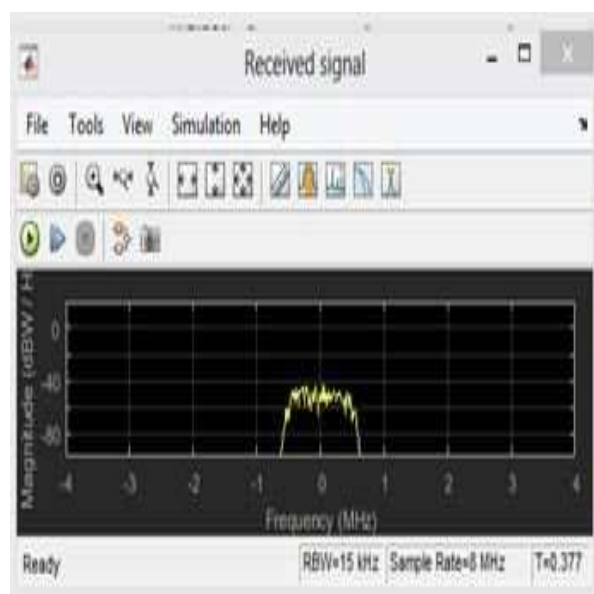

Figure 4.14.Received signal for simulation for case 3

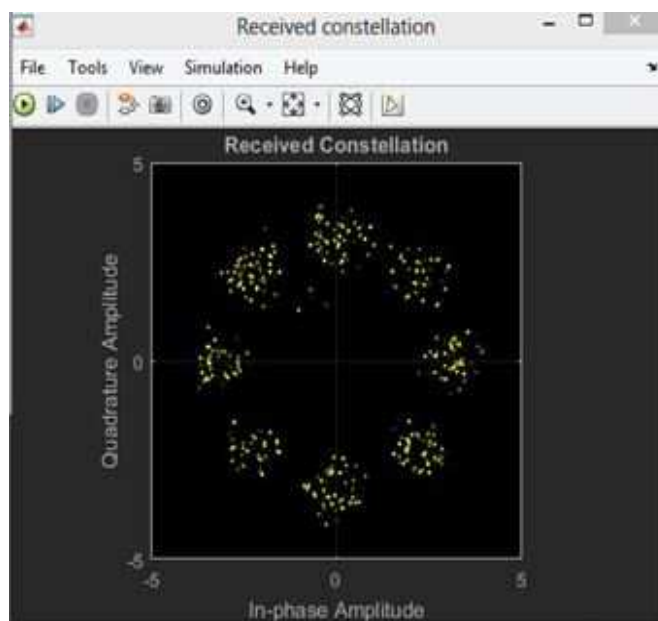

Figure 4.15. Received constellations for case 3 simulation

The diagram in figure 4.6 to 4.10 shows the simulation result when sectoring is applied. The channels occupied by the interfering signals. A sectoring scheme of 120 degrees was implemented. The result of sectoring can be seen in the increased signal to noise to interference ratio and consequent reduced Bit Error Rate. The constellations diagram shows a more organized constellation plots.

Further reduction of co-channel interference can be achieved by raising the power level of the transmitted signal.

The power gain block is opened and the value of the transmit power of the desired signal is dynamically varied. This reveals that the bit error reduced to zero when the power of the desired

signal is varied between 1dB-10dB and it suggest that a better reception occurs at the transmit power of 10dB. The plots below show the effect of increasing the power of the transmitted signal. The constellations diagram shows even much more organized plots. It is easy to see that there are 8 received constellations points which corresponds to an 8-PSK signal.

**DISCUSSIONS**

At the end of the three simulation cases, major differences are recorded when the three cases are being compared. These differences are measured in terms of the received constellations, Bit Error Rate, and signal to interference ratio. This briefly tabulated as shown below:

Table 2. Comparison of three simulation cases

	Simulation case 1 (Without sectoring)	Simulation case2 (With sectoring)	Simulation case3 (With sectoring + increased power of transmitted signal)
BER (bit error rate)	[0.345 3507 1.016*10 <sup>4</sup> ]	[0.09416 957 1.016*10 <sup>4</sup> ]	[0 0 1.016*10 <sup>4</sup> ]
S/I	2.255	2.690	7.58

Table 3. Transmit Power versus system performance without sectoring

P <sub>o</sub> (dB)	SIR (dB)	BER (dB)	No. of Bits Trans-Mitted In Error	Total Bits Transmitt-Ed
1	3.53	-4.62	3507	1.016*10 <sup>4</sup>
2	4.03	-5.13	3120	1.016*10 <sup>4</sup>
3	4.53	-5.81	2665	1.016*10 <sup>4</sup>
4	5.03	-6.53	2261	1.016*10 <sup>4</sup>
5	5.53	-7.12	1975	1.016*10 <sup>4</sup>
6	6.03	-7.61	1762	1.016*10 <sup>4</sup>
7	6.53	-8.10	1574	1.016*10 <sup>4</sup>
8	7.03	-8.84	1326	1.016*10 <sup>4</sup>
9	7.53	-10.11	990	1.016*10 <sup>4</sup>
10	8.03	-12.30	599	1.016*10 <sup>4</sup>
11	8.53	-15.84	265	1.016*10 <sup>4</sup>
12	9.03	-22.44	58	1.016*10 <sup>4</sup>
13	9.53	-33.08	5	1.016*10 <sup>4</sup>
14	10.03	0	0	1.016*10 <sup>4</sup>

Table 4. Transmit Power versus system performance with 120 degrees sectoring

P <sub>o</sub> (dB)	SIR (dB)	BER (dB)	No. of bits transmitted in error	Total bits transmitted
1	4.30	-10.26	957	1.016*10 <sup>4</sup>
2	4.80	-11.30	753	1.016*10 <sup>4</sup>
3	5.30	-12.68	549	1.016*10 <sup>4</sup>
4	5.80	-14.58	354	1.016*10 <sup>4</sup>
5	6.30	-17.17	195	1.016*10 <sup>4</sup>
6	6.80	-20.68	57	1.016*10 <sup>4</sup>
7	7.30	-25.76	27	1.016*10 <sup>4</sup>
8	7.80	-31.62	7	1.016*10 <sup>4</sup>
9	8.30	-35.30	3	1.016*10 <sup>4</sup>
10	8.80	0	0	1.016*10 <sup>4</sup>
11	9.30	0	0	1.016*10 <sup>4</sup>
12	9.80	0	0	1.016*10 <sup>4</sup>
13	10.30	0	0	1.016*10 <sup>4</sup>
14	10.80	0	0	1.016*10 <sup>4</sup>

The results when compared shows that sectoring helps reduces co-channel interference as it reduces the bit error rate by almost 5.6dB (55%) and increased signal-to-noise ratio by 0.77dB(21.8%). Furthermore, by dynamically increasing the transmit power of the desired from 1dB-10dB with sectoring yields a more substantial Signal-to-interference ratio of about 4.5dB , zero bit error rate and power saving of 4dB.

## CONCLUSION

This thesis employs 120 degrees sectoring to reduce co-channel interference in wireless cellular network. Only first tier is considered owing to the fact that the interference from the subsequent tiers is negligible. Similarly, only the reverse link of a code division multiple access (CDMA) system is considered and because of sectoring, the number of interfering mobiles

decreases with increase in the number of sectors. The result is shown in terms of signal to interference ratio (SIR), bit error rate (BER) and the received signal constellation.

Simulation of the system is done in matlab and in three cases namely, case 1, case 2 and case 3. Case 1 shows the behaviours of the system without sectoring. The result bit error rate and signal-to-interference ratio of 4.62dB and 3.53dB respectively. The scattered constellation of the received signal implies that the receiver is prone to make a lot of decision errors. Case 2 result shows 55% (5.6dB) and 21.8% (0.77dB) improvement in the bit error rate (BER) and signal-to-interference ratio (SIR) respectively. Case 3 shows the behavior of the system due to the combined effect of dynamic increase transmits power of the desired signal and 120 degrees sectoring. The bit error rate dropped to zero with additional 4.5dB improvement in signal to interference ratio. This suggests that this research will be well suited in a cellular network whose architecture employs dynamic transmit power mechanism.

## REFERENCES

- [1]. Abhinav, K. and Vinay, V. (2014). Study on improving coverage area by cell splitting and cell sectoring methods in cellular system. *International Journal of advanced research in computer science and software engineering*. Vol. 4, Pp. 813-814.
- [2]. Adem Durak. (1999). "Evaluation and methods to reduce Cochannel interference on the reverse channel of a CDMA cellular system", *DTIC quality inspected*, Pp. 18-20.
- [3]. Ahaneku, M.A. & Chinjundu, V.C. (2013). "Frequency Reuse and Implications of Limited Network Resources in Cellular Mobile Systems", Pp. 167-171.
- [4]. Ahmed, Mohammed Abdelsalam Ahmed and Marsland, I. M. (2008). "Cochannel Interference Cancellation in Wireless Cellular Networks". Pp. 698-702.
- [5]. Andrea, Goldsmith. (2004). "Wireless communications". Stanford University. Pp. 10-14.
- [6]. Ball, C.F., and Ivanov, H.K., (2005). "Spectrum efficiency evaluation for different wireless technology based on traffic modeling", *IEEE international Symposium on personal indoor and mobile radio communications workshop*, Vol. 3, Pp. 2055-2061.
- [7]. Carl, Carter. (1997). Principles of global positioning system. Allen Osborne Associates, Pp. 1- 9.
- [8]. Elena, Lopez-Agulera and Jordi, Casademont. (2006). A transmit power control proposal for IEEE 802.11 cellular networks. IEEE, 6<sup>th</sup> international workshop on application and services in wireless networks. Pp. 1-8.
- [9]. Hale, W.K. (1980). "Frequency Assignment Theory and Application". www.ieeeexplore.ieee.org. Pp. 1497-1514.
- [10]. Ho-Shin, Cho. (2001). "Protection against Cochannel Interference from Neighboring Cells Using Down-Tilting of Antenna Beams". Pp. 1553-1557.
- [11]. Jens, Zander. (1994). Transmitter power control for Cochannel interference Management in cellular radio systems. Springer science and business media, Pp. 161-175.
- [12]. Jiang, L.I., Dongdong, L.I., Jaber, A., Khoja, Qilian, Liang, Micheal, Mary, T. and Vasant, K. Probhu. (2003). "Overcoming Cochannel Interference in TDMA systems Using SOM Equalizer". Pp. 123-126.
- [13]. Minh, A. Nguyen. (2005). "Interference Cancellation Receiver", *NASA publishers*, Pp. 1-6.
- [14]. Muhammed, Ali Qureshi, Alodul, Aziz and Hussaia, Bakhsh. (2010). CIR improvement in a cellular mobile system using Beamforming and power control. IEEE, Pp. 294-297.



- [15]. Nisha, Sunil Kumar and Jyoti, Bhatnager. (2013). Hand off strategies in cellular system. *International Journal of new trends in electronics and communication*. Vol. 1, Pp. 22-26.
- [16]. Ohaneme. C.O., Idigo, V.E., and Ifeagwu, E.N. (2012). Analysis of interference and channel capacity in a CDMA wireless network using dynamic channel assignment strategy. *International journal of computer networks and communication*. vol 4, No. 5, Pp. 149-163.
- [17]. Reza, Berang. (1998). "Cochannel Interference Cancellation in Mobile Cellular Communication Systems. Victoria University of Technology Library", *Kluwer Academic Publishers*, Pp. 21-71.
- [18]. Saad, G. Kiani and David, Gesbert. (2006). Optimal and distributed scheduling for multicell capacity maximization. *IEEE International symposium on information theory*, Pp. 1-29.
- [19]. Sirikiat, Lek Ariyavisitakul, Jack, H. Winters and Nelson R. Sollenberger. (2000). "Joint Equalization and Interference Suppression for High Data Rate Wireless Systems", *IEEE Journal on Selected Areas in Communications*, Vol. 18.
- [20]. Tasher, Ali Sheikh, Deboray, Muchahary and Khanjan, Changmai. (2014). A survey of reduction the interference on cellular communication system. *International Journal of computer application* . Vol.95, Pp. 40-41.
- [21]. Teruya, Fujii and Masayuki, Sakamoto. (1988). Reduction of Cochannel interference in cellular systems by intra-zone channel reassignment *IEEE*, Pp. 668-672.
- [22]. Tuan NGNYEN (2006), "Null Depth Trade off for output Power Reduction in a Downlink Adaptive Antenna Array", *IEEE International Symposium on Wireless Personal Multimedia Communications-Bangkok, 2000*.